

BIXOLON®
SAMSUNG mini printers



USER'S MANUAL

Manual del usuario / Benutzerhandbuch

Manuel d'utilisation / Manuale d'Uso

Руководство пользователя / ユーザーマニュアル / 사용 설명서

STP-103

THERMAL PRINTER

IMPRESORA TÉRMICA / THERMODRUCKER

IMPRIMANTE THERMIQUE / STAMPANTE TERMICA

ТЕРМО ПРИНТЕР / 感熱式プリンター / 감열식 프린터

Tellermate

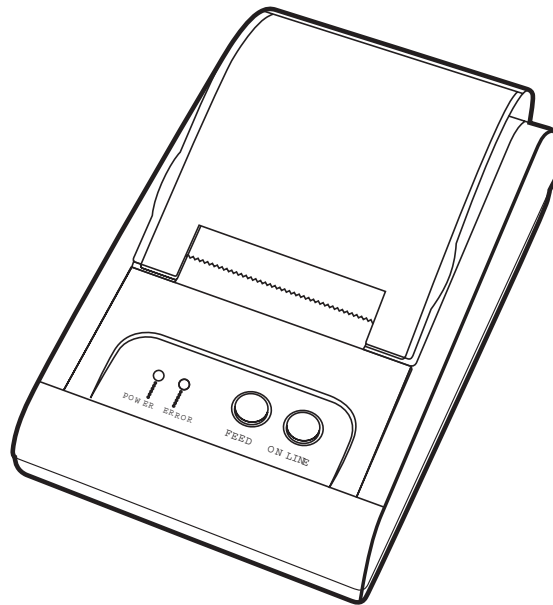





www.samsungminiprinters.com



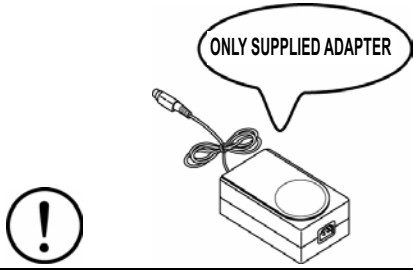

www.tellermate.com

English

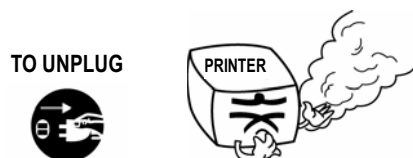
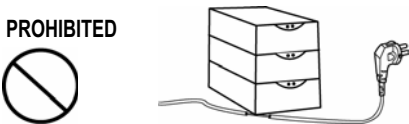
Safety Precautions

When using this appliance, please follow these safety regulations in order to prevent any hazard or material damage.

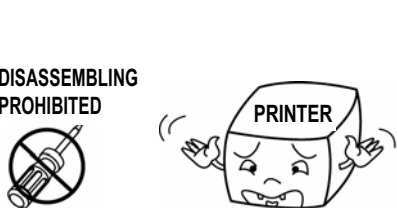
 WARNING Not following instructions can cause serious injury or death.	
<p>Do not plug several products in one multi power extension.</p> <ul style="list-style-type: none">• This can cause over-heating and fire.• If the plug is wet or dirty, dry or wipe it before use.• If the plug does not fit perfectly with the outlet, do not plug in.• Be sure to use only standardized multi-outlets. <p>PROHIBITED</p> 	<p>Only use the supplied adapter.</p> <ul style="list-style-type: none">• It is dangerous to use other adapters. 
<p>Do not pull the cable to unplug it.</p> <ul style="list-style-type: none">• This can damage the cable, which can then cause a fire or a breakdown of the printer. <p>PROHIBITED</p> 	<p>Keep packaging out of children's reach.</p> <ul style="list-style-type: none">• Plastic bags cause danger of suffocation. <p>PROHIBITED</p> 
<p>Do not plug in or unplug with wet hands.</p> <ul style="list-style-type: none">• You can be electrocuted. <p>PROHIBITED</p> 	<p>If you notice unusual smoke, odor or noise from the printer, unplug it and then take the following actions :</p> <ul style="list-style-type: none">• Switch off the printer and unplug the set from the mains.• After the smoke disappears, call your dealer to repair it. <p>TO UNPLUG</p> 
<p>Do not bend the cable by force or leave it under any heavy object.</p> <ul style="list-style-type: none">• Damaged cables can cause a fire. <p>PROHIBITED</p> 	

 CAUTION Not following instructions can cause injury or damage the appliance.	
<p>Keep the desiccant out of children's reach.</p> <ul style="list-style-type: none"> • If not, they may eat it. 	<p>Install the printer on the stable surface.</p> <ul style="list-style-type: none"> • If the printer drops or falls, it may break or cause injury.
<p>PROHIBITED</p> 	<p>PROHIBITED</p> 
<p>Only use approved accessories and do not try to disassemble, repair or remodel the printer for yourself.</p> <ul style="list-style-type: none"> • Call your dealer when you need these services. 	<p>Do not use the printer when it is out of order. This can cause fire or an electrocution.</p> <ul style="list-style-type: none"> • Switch off and unplug the printer before calling your dealer.
<p>DISASSEMBLING PROHIBITED</p> 	<p>TO UNPLUG</p> 
<p>Do not let water or other foreign objects in the printer.</p> <ul style="list-style-type: none"> • If this happens, switch off and unplug the printer before calling your dealer. 	
<p>PROHIBITED</p> 	

English

Warning – U.S.A

This equipment has been tested and found to comply with the limits for a Class A digital device, pursuant to Part 15 of the FCC Rules. These limits are designed to provide reasonable protection against harmful interference when the equipment is operated in a commercial environment. This equipment generates, uses, and can radiate radio frequency energy and, if not installed and used in accordance with the instruction manual, may cause harmful interference to radio communications. Operation of this equipment in a residential area is likely to cause harmful interference in which case the user will be required to correct the interference at his own expense.

This equipment has been tested and found to comply with the limits for a Class B digital device, pursuant to Part 15 of the FCC Rules. These limits are designed to provide reasonable protection against harmful interference in a residential installation. This equipment generates, uses and can radiate radio frequency energy and, if not installed and used in accordance with the instructions, may cause harmful interference to radio communications. However, there is no guarantee that interference will not occur in a particular installation. If this equipment does cause harmful interference to radio or television reception, which can be determined by turning the equipment off and on, the user is encouraged to try to correct the interference by one or more of the following measures:

- Reorient or relocate the receiving antenna.
- Increase the separation between the equipment and receiver.
- Connect the equipment into an outlet on a circuit different from that to which the receiver is connected.
- Consult the dealer or an experienced radio/TV technician for help.

Notice - Canada

This Apparatus complies with class "A" limits for radio interference as specified in the Canadian department of communications radio interference regulations.

WEEE Marking



This marking shown on the product or its literature, indicates that it should not be disposed with other household waste at the end of its working life. To prevent possible harm to the environment or human health from uncontrolled waste disposal, please separate this from other types of wastes and recycle it responsibly to promote the sustainable reuse of material resources. Household users should contact either the retailer where they purchased this product, or their local government office, for details of where and how they can take this item for environmentally safe recycling. Business users should contact their supplier and check the terms and conditions of the purchase contract. This product should not be mixed with other commercial wastes for disposal.

Declaration of Conformity

BIXOLON CO.,LTD

Thermal Printer

STP103

Reference Report No. : DR501203012AA

The above product has successfully demonstrated that its product is in compliance with

Electromagnetic Compatibility Directive 89/336/EEC

EN55022 Class A : 1998+A 1 : 2000

EN55024 : 1998 :+A1:2001

(EN61000-4-2 : 1995+A1 :1998+A2:2001)

(EN61000-4-3 : 1996+A1 :1998+A2:2001)

(EN61000-4-4: 1995+A1 : 2001)

(EN61000-4-5 : 1995+A1 : 2001)

(EN61000-4-6 : 1996+A1 : 2001)

(EN61000-4-11 : 1994+A1 : 2001)

The above product's beginning Serial No.

Year of manufacture : 2004

We. The undersigned. Hereby declare that the equipment specified above conforms to the above Directive(s)

Manufacturer Signature

BIXOLON CO.,LTD

BIXOLON Co.,Ltd

A-502, Digital Empire, 980-3 Yeongtong-dong, Yeongtong-gu,

Suwon-si, South Korea

443-813

English

Introduction

The main features of the printer are as follows:

1. High speed printing
2. Low noise thermal printing
3. RS232 serial interface
4. Data buffer allowing the unit to receive print data even during printing.

Please be sure to read the instruction in this manual carefully before using your new STP-103.

NOTE

The socket-outlet shall be near the equipment and it shall be easy accessible.

Table of Contents

Chapter 1. Unpacking	7
1-1. Checking the contents of the Printer	7
1-2. Locating the Printer	7
1-3. Printer Part names	8
1-4. Operating Control Panel	9
Chapter 2. Connecting the cable	10
2-1. Connecting the AC adapter to your printer	10
2-2. Connecting the Printer to your computer	11
Chapter 3. Installing the Paper Roll	12
Chapter 4. Setting the DIP Switching	13
Chapter 5. Running the Self Test	15
Appendix A. Connector	16
Appendix B. Specification	16
Appendix C. Spares and Consumables	17
Appendix D. Contact Numbers	18

English

Chapter 1. Unpacking

1-1. Checking the contents of the Printer

The items illustrated below are included with your printer.
If any items are damaged or missing, please contact your dealer for assistance.

Unpacking

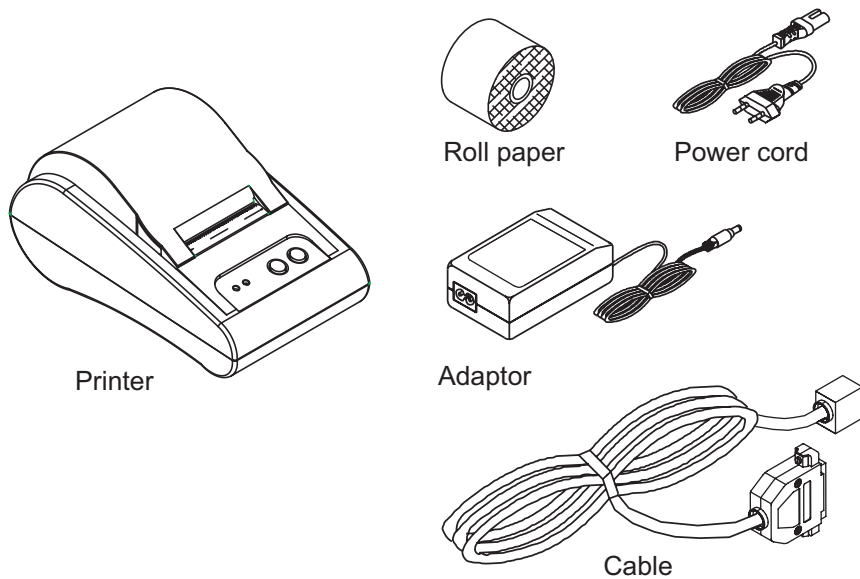

1-2. Locating the Printer

Avoid direct sunlight or excessive heat.
Avoid storing the printer in the places subject to excessive moisture.
Avoid places subject to intense vibration or shock.
Make sure that there is enough space around the printer so that it can be used easily.

1-3. Printer Part Names

- (1) Cover top
- (2) Case top
- (3) Case bottom
- (4) Control panel
- (5) Roller
- (6) Power switch
- (7) Interface connector (male)
- (8) DC Jack
- (9) Paper roll
- (10) Detector switch

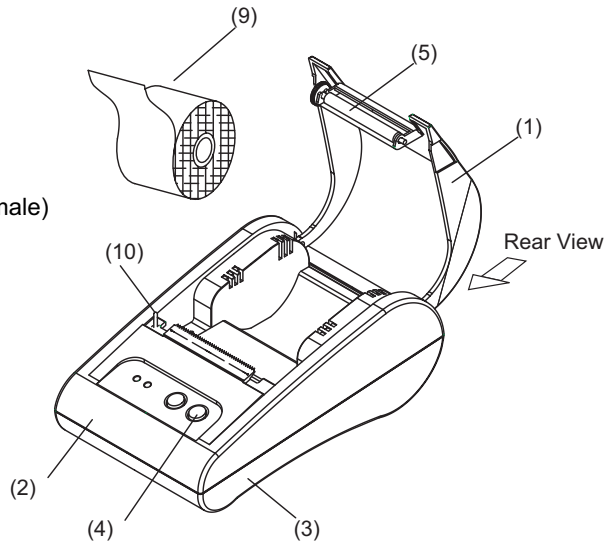

Rear View

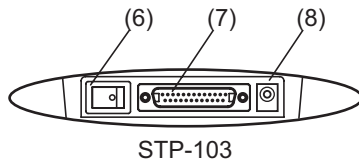

Control Panel

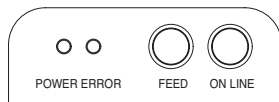

English

1-4. Operating Control Panel

The control panel has two buttons and two lights.



Buttons

The control panel buttons allow paper feed and on line activation.

ON LINE

This button is not active in the custom firmware in this printer.

FEED

Press the FEED button once to advance paper one line. You may also press the FEED button continuously to feed paper continuously. The FEED button is always active.

Indicator Lights

The control panel lights provide information on printer conditions.

POWER (green)

The POWER light is on when printer power is on.

ERROR (red)

- 1) The error LED blinks quickly when paper is out.
- 2) The error LED blinks when the Near End Sensor (paper low) is triggered .

Chapter 2. Connecting the Cable

2-1. Connecting the AC adapter to your printer

To power up the printer, only use the AC adapter, NH36-240150-11.

WARNING

Using an incorrect power supply may cause fire or electrocution and is at the customers' risk.

CAUTION

When connecting or disconnecting the power supply from the printer, make sure that the power supply is not plugged into an electrical outlet ; otherwise you may damage the power supply or the printer

1. Make sure that the printer's power switch is turned off, and that the power supply's power cord is unplugged from the electrical outlet.
2. Check the label on the power supply to make sure that the required voltage matches that of your electrical outlet.
3. Plug the power supply's DC cable connector into the printer's power connector as shown below.

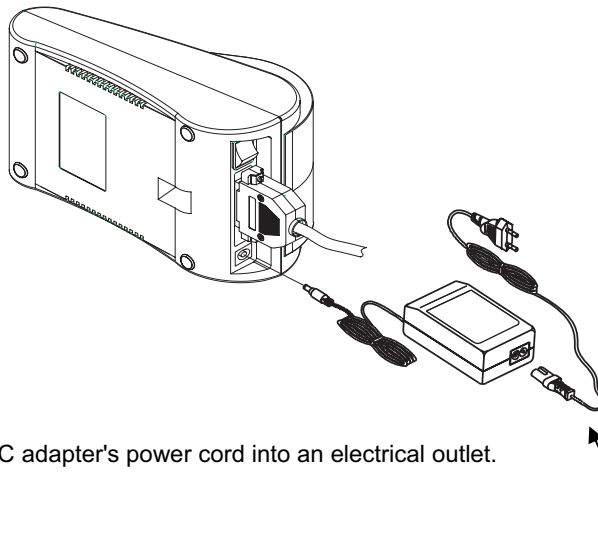

4. Plug the AC adapter's power cord into an electrical outlet.

NOTE

To remove the DC cable connector grasp the connector at the inlet to the supply and pull it straight out. Make sure that the main unit's power cord is unplugged before you disconnect the DC cable connector.

English

2-2. Tellermate Product – refer to your Tellermate Operation manual for details

You need an appropriate serial interface cable to connect your Tellermate to the printer's built-in interface.

1. Make sure that both the printer and TY are turned off :
then plug the cable connector securely into the printer's interface connector.
2. Tighten the screws on **both** sides of the cable connector.

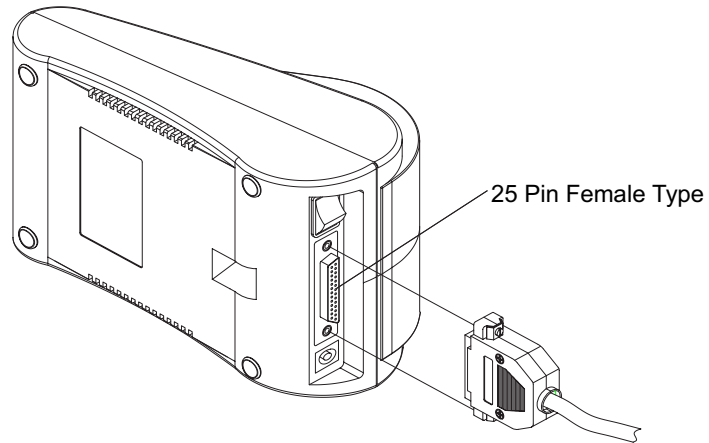

3. Plug the other end of the cable into the Tellermate equipment.

Chapter 3. Installing Paper Rolls

Use a paper roll that matches the specifications – See Appendix C.

NOTE

The printer must be turned off before installing the paper roll.

1. Open the printer cover and remove the used paper roll core if there is one.
2. Insert the paper roll as shown below.

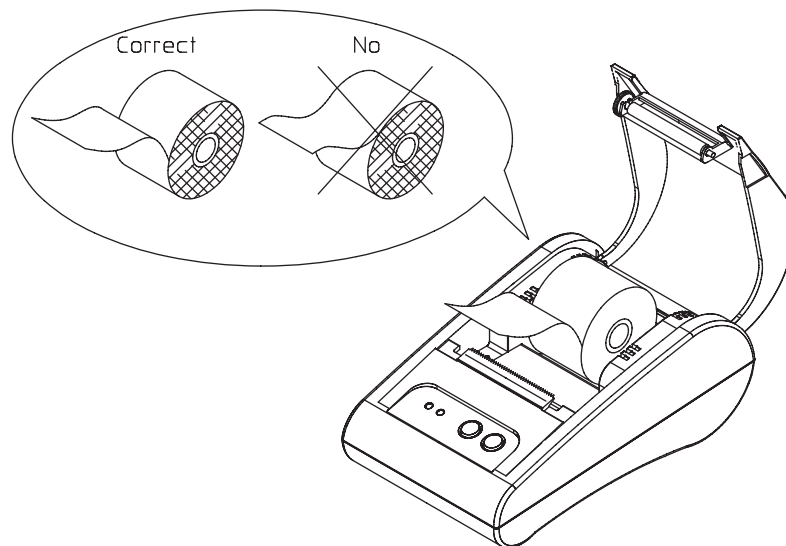

3. Pull out the paper roll until the paper comes out from the top of the printer. Then close the printer cover using both hands, one on either side of the printer. Both sides of the printer lid must be pressed down so they click into place.
4. Turn the printer on.

English

Chapter 4. Setting the DIP Switches

CAUTION

The DIP switch settings control the operation of the printer, changing the settings may mean that the printer will not communicate correctly to your Tellermate equipment. Only change these settings as directed by your Tellermate Customer Care Representative or Tellermate Authorised Distributor.

Turn off the printer while setting the DIP switch to prevent an electrical short, which may damage the printer.

1. Make sure the printer is turned off.
2. Remove the rubber bung covering the DIP switches.
3. There is a row of switches on the bottom of the printer. Notice that ON position is marked on each set of switches.

Use tweezers or some other narrow tool to move the switches.

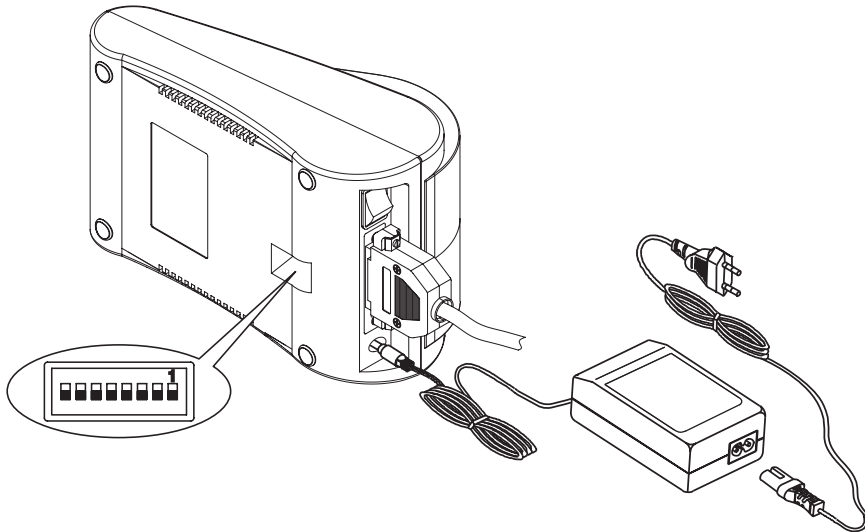

4. Use the following table to set the DIP switches.
5. Replace the rubber bung.

DIP Switch Functions

No	Function	On	Off
1	* Serial Baudrate Setting		
2			
3			
4	Hand-Shaking	Xon/Xoff	DTR/DSR
5	** Default Code Page Setting		
6			
7			
8	Reserved		Off

* Baud rate	1	2	3
2400bps	On	Off	Off
4800bps	Off	On	Off
9600bps	Off	Off	On
19200bps	On	Off	On
38400bps	On	On	Off
57600bps	Off	On	On
115200bps	On	On	On

** Code Page	5	6	7
CP1250	Off	Off	Off
CP1251	Off	Off	On
CP1252	Off	On	Off
CP1253	Off	On	On
CP1254	On	Off	Off
T. E. Eur	On	Off	On
T. Japan	On	On	Off
T. Int'l	On	On	On

T. Eur is Tellermate Eastern European font
T. Japan is Tellermate Japan font
T. Int'l is Tellermate International font

English

Chapter 5. Running the Self-test

1. Self-test printing

1) Starting the self test

To start printing the self-test on a paper roll, hold down the PAPER FEED button and turn on the printer with the cover closed. The self-test prints the current printer settings, which provide the following information :

- control software version
- dip switch state

2) Standby state

After printing the current printer status, the printer prints the message "Please press the FEED BUTTON.". The LED indicator blinks and the printer enter the test printing standby state.
Press the FEED BUTTON to start test printing.

2. Ending the self-test

After a number of lines are printed, the printer indicates the end of the self-test by printing " ** TEST COMPLETED ** ".

If the self-test is not completed, then you must turn your printer OFF and ON.

Appendix A. Connector

Serial Interface Connector

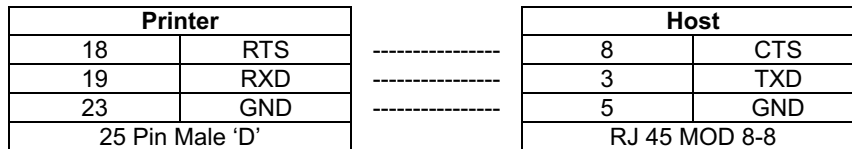

Tellermate part number: 805 064P

Appendix B. Specification

Printing method	Thermal line printing	
Dot density	200 x 200 Dpi (8 dot/mm)	
Printing width	48mm	
Paper width	58mm	
Characters per line	42 (Font B) (9x24)	
Printing Speed	Approximately 1.97 inches / sec 50 mm/sec at 25°C/printing duty 12.5%	
Receive buffer size	15K bytes	
Supply voltage	DC	24V 1.5A
Environmental conditions	Temperature	0 ~ 40° (operating) -10 ~ 50° (storage)
	Humidity	30 ~ 80% RH (operating) 10 ~ 90% RH (storage)
MCBF	Mechanical	15,000,000 line
	Head	50 million pulse (about 50km)
Paper	Thickness	0.06 ~ 0.09mm
	Roll size	Ø60 ~ 57 (w)
	Roll spool diameter	Inside : Ø12mm (0.47") Outside : Ø18mm (0.71")

English

Appendix C. Spares and Consumables

Spares for the printer may be purchased from Tellermate or your Tellermate Distributor.

<u>Part Number</u>	<u>Description</u>
805 064P	STP-103 Serial Cable
904 155W	Power Adaptor NH36-240150-I1
621 533W	Printer Plastic Cover Top
805 151C	Mains Lead – GB
805 152P	Mains Lead – Europe
805 188E	Mains Lead – Japan
805 148A	Mains Lead – USA
805 189R	Mains Lead – Republic South Africa
805 190V	Mains Lead – Australia / New Zealand
904 801A	Printer user manual
650 062J	Dip Switch Rubber Bung
950 224R	Print head cleaning pen
904 149K	Approved paper rolls are supplied in boxes of 20 and may be purchased from Tellermate or your Tellermate Distributor.

See Appendix D for contact numbers

Appendix D. Contact Details

<u>Country</u>	<u>Contact</u>
USA	1-800-TELMATE (835-6283)
UK	0870 78 77 087
FRANCE	0899 70 10 72
GERMANY	0180 58 35 537
SWITZERLAND	0848 83 55 37
AUSTRIA	0810 00 12 50
SPAIN	900 50 58 99
RSA	011 467 44 90

Internet: www.tellermate.com